

PARTS LIST						
ITEM	QTY	PART NO.	PART DESCRIPTION	LENGTH	UNIT WT.	NET WT.
1	1	FACE-ASY1-NP	SINGLE SECTOR FACE MOUNT KIT (NO PIPE)		565.23	565.23
2	1	FACE-PM496	FACE ASSEMBLY PIPE MOUNT KIT		145.77	145.77
3	1	FSP296-K	FACE STRUT PIPE KIT 2-3/8" X 96"		80.08	80.08
4	2	P3252	3" SCH. 40 PIPE (3.5" O.D. X 0.226" - A53 GR. B Fy=35 ksi min)	252 in	169.03	338.07
					TOTAL WT. #	1110.01

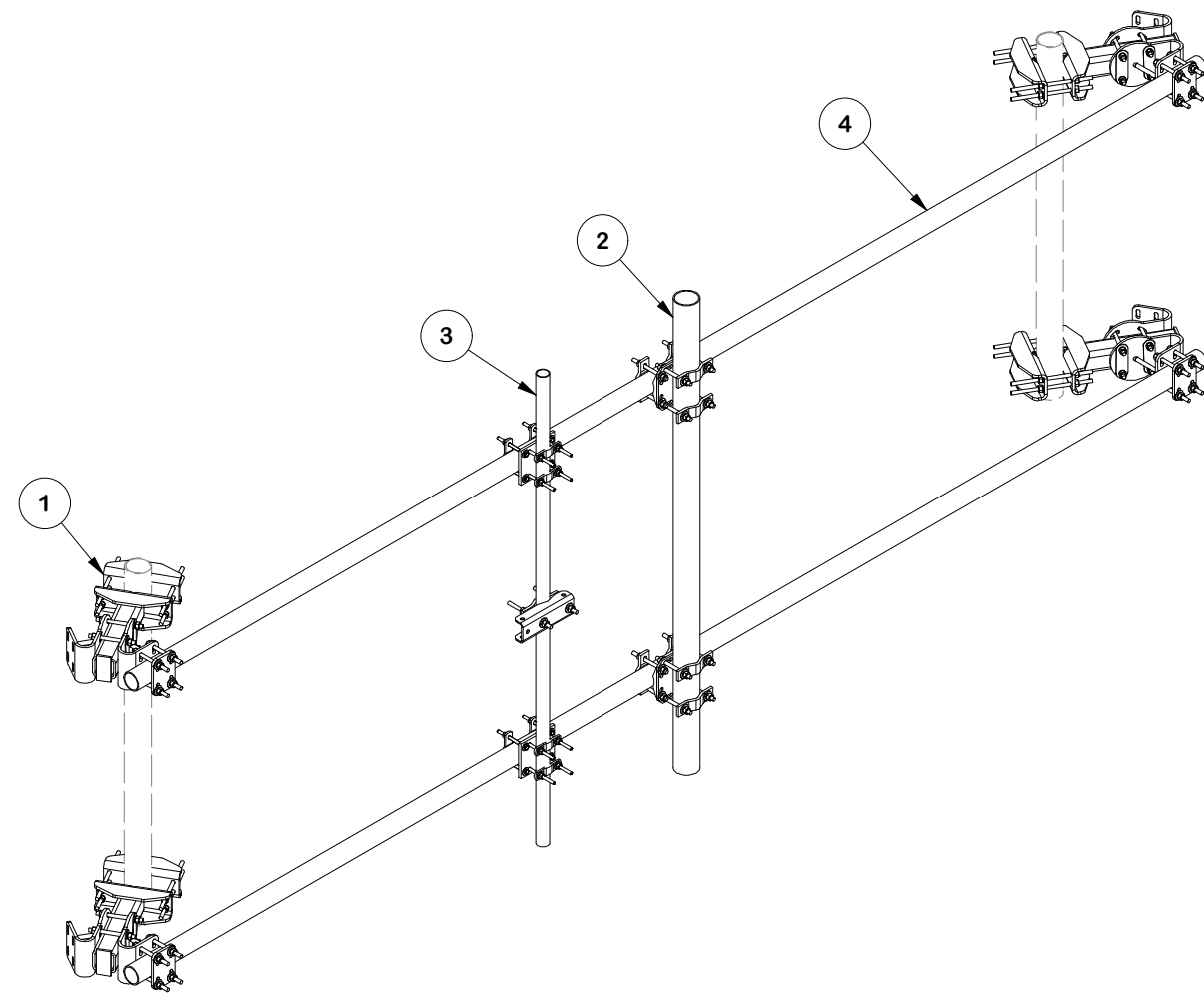
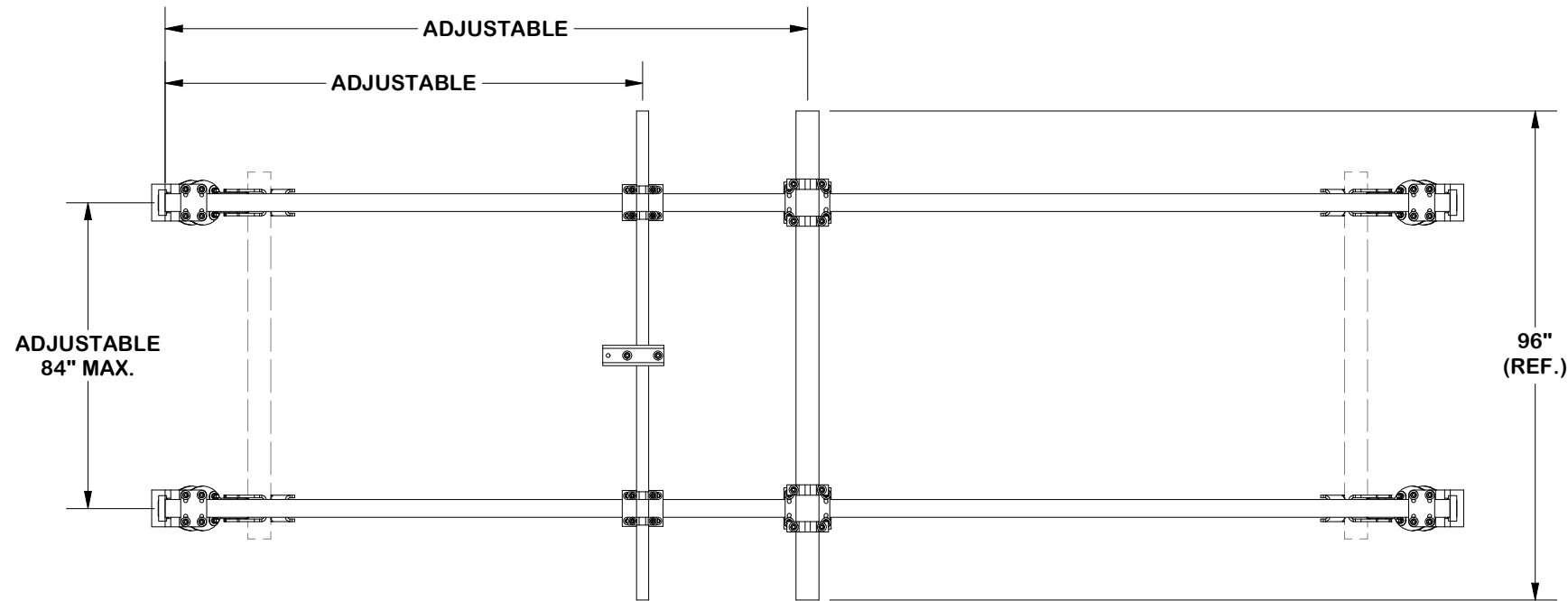
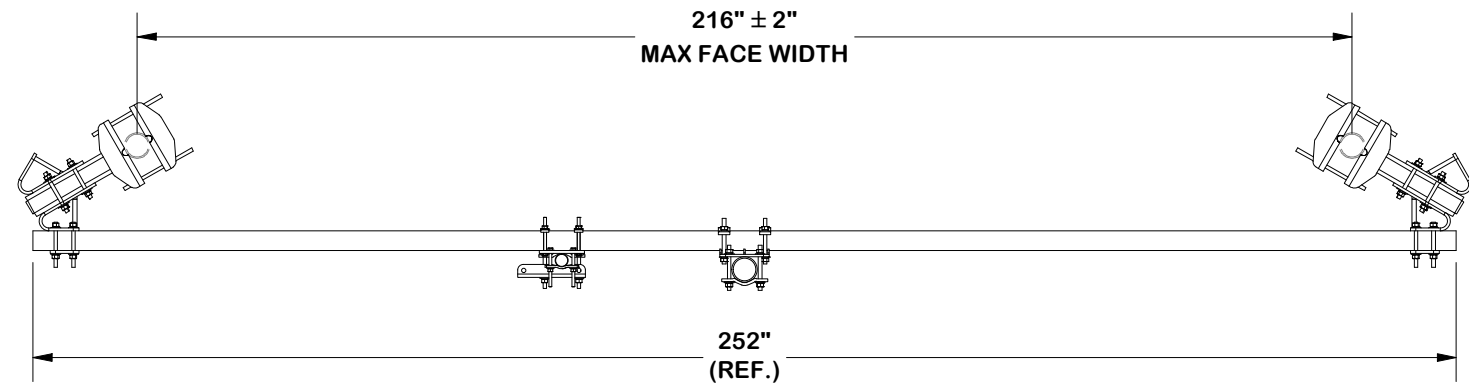

FINISH:
HOT DIP GALVANIZED.

TOLERANCE NOTES

TOLERANCES ON DIMENSIONS, UNLESS OTHERWISE NOTED ARE:
 SAWED, SHEARED AND GAS CUT EDGES ($\pm 0.030"$)
 DRILLED AND GAS CUT HOLES ($\pm 0.030"$) - NO CONING OF HOLES
 LASER CUT EDGES AND HOLES ($\pm 0.010"$) - NO CONING OF HOLES
 BENDS AND ANGLES ARE $\pm 1/2$ DEGREE
 ALL OTHER MACHINING ($\pm 0.030"$)
 ALL OTHER ASSEMBLY ($\pm 0.060"$)

PATENT INFORMATION: WWW.SITEPRO1.COM/PATENTS

PROPRIETARY NOTE:
 THE DATA AND TECHNIQUES CONTAINED IN THIS DRAWING ARE PROPRIETARY INFORMATION OF VALMONT INDUSTRIES AND CONSIDERED A TRADE SECRET. ANY USE OR DISCLOSURE WITHOUT THE CONSENT OF VALMONT INDUSTRIES IS STRICTLY PROHIBITED.

DESCRIPTION
**SINGLE-SECTOR MICROWAVE KIT
 W/ 3-1/2" DIA. X 252" HORIZONTALS
 AND PIPE MOUNT AND SINGLE STRUT**

CPD NO. SP1	DRAWN BY SDR 3/6/2026	ENG. APPROVAL 3/11/2026
CLASS 87	SUB 02	DRAWING USAGE CUSTOMER
CHECKED BY CSL 3/11/2026		



Engineering Support Team:
 sp1engineering@valmont.com

A valmont COMPANY

PART NO. FMW20-3SS
DWG. NO. FMW20-3SS

NOTES:

1. THE MAXIMUM TAPER ADJUSTMENT IS 8° BASED UPON 60" SPACING OF ADJUSTABLE MOUNTING BRACKETS.

PARTS LIST						
ITEM	QTY	PART NO.	BOX NO.	PART DESCRIPTION	UNIT WT.	NET WT.
1	8	FACE-CCHALF	P-FACE-CCHALF	FACE ASSEMBLY CORNER CONNECTION (HALF)	33.15	265.20
2	4	FACE-LC	P-FACE-LC	FACE ASSEMBLY LEG CONNECTION	26.99	107.96
3	4	X-FACE-TW		TUBE WELDMENT	48.02	192.07
TOTAL WT. #					565.23	

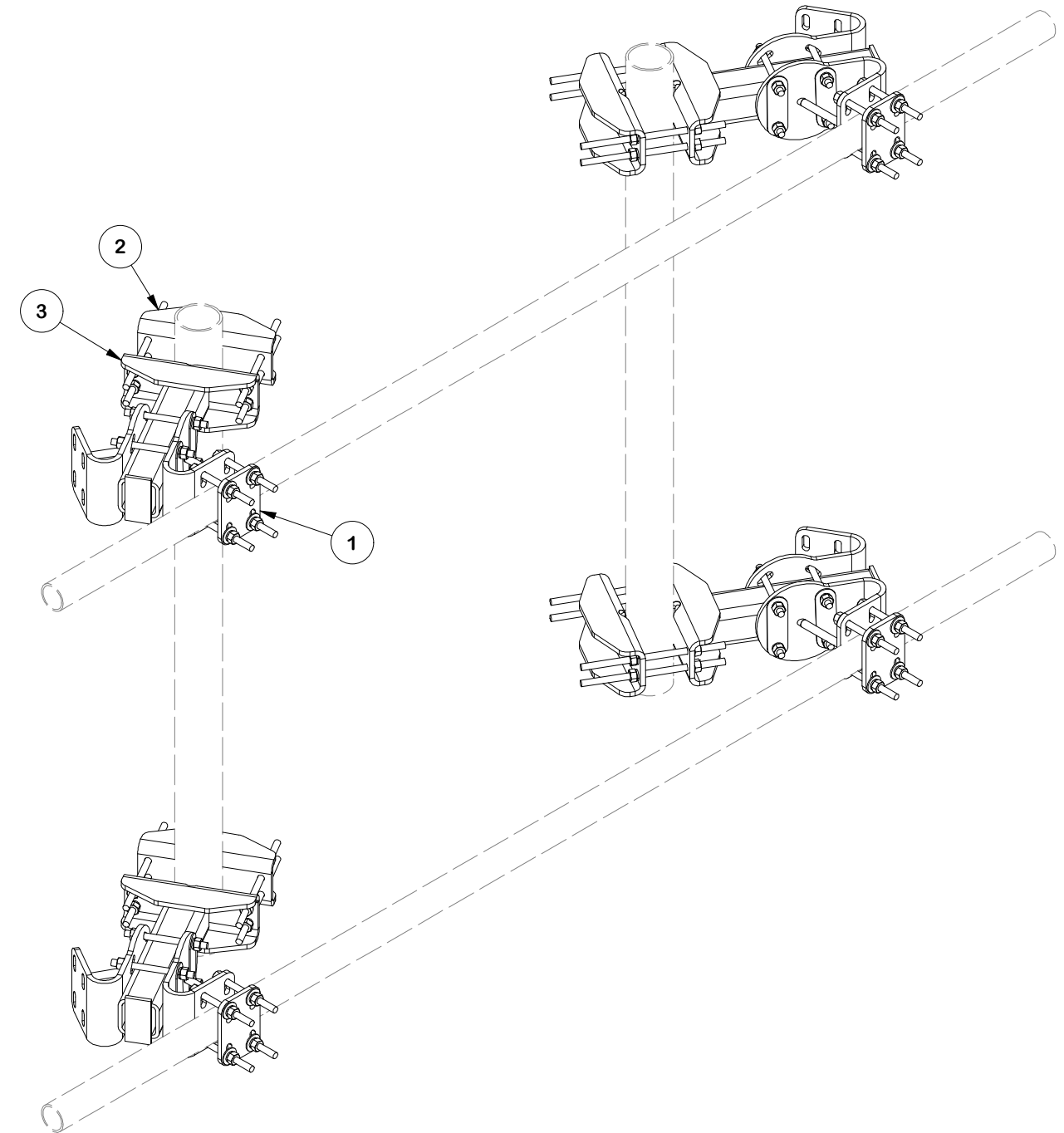
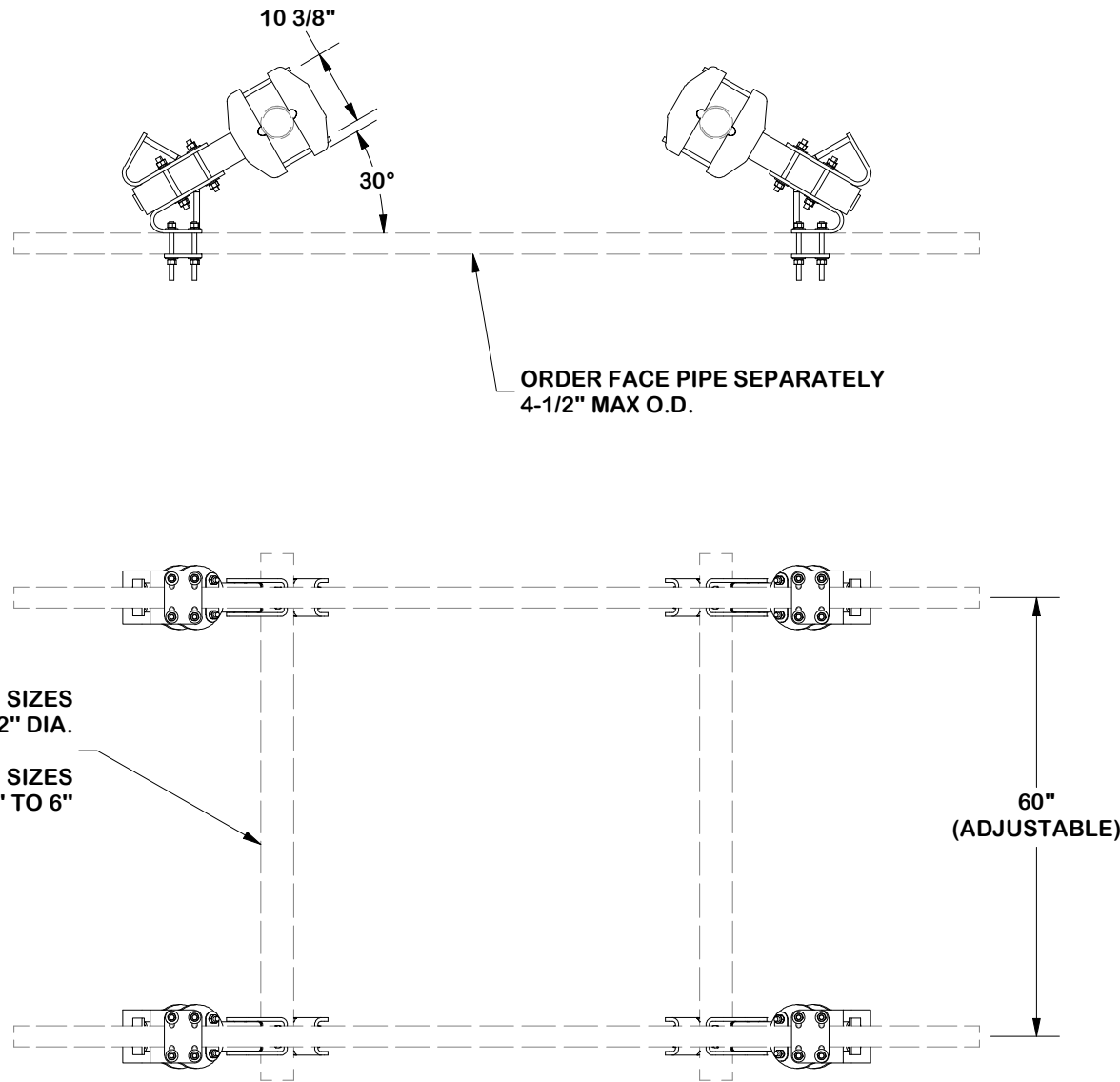

FINISH:
HOT DIP GALVANIZED.

TOLERANCE NOTES

TOLERANCES ON DIMENSIONS, UNLESS OTHERWISE NOTED ARE:
 SAWED, SHEARED AND GAS CUT EDGES ($\pm 0.030"$)
 DRILLED AND GAS CUT HOLES ($\pm 0.030"$) - NO CONING OF HOLES
 LASER CUT EDGES AND HOLES ($\pm 0.010"$) - NO CONING OF HOLES
 BENDS AND ANGLES ARE $\pm 1/2$ DEGREE
 ALL OTHER MACHINING ($\pm 0.030"$)
 ALL OTHER ASSEMBLY ($\pm 0.060"$)

PROPRIETARY NOTE:
 THE DATA AND TECHNIQUES CONTAINED IN THIS DRAWING ARE PROPRIETARY INFORMATION OF VALMONT INDUSTRIES AND CONSIDERED A TRADE SECRET. ANY USE OR DISCLOSURE WITHOUT THE CONSENT OF VALMONT INDUSTRIES IS STRICTLY PROHIBITED.

DESCRIPTION
**SINGLE-SECTOR MICROWAVE KIT
 W/ 3-1/2" DIA. X 252" HORIZONTALS
 AND PIPE MOUNT AND SINGLE STRUT**



Engineering Support Team:
 sp1engineering@valmont.com

REV	DESCRIPTION OF REVISIONS	CPD	BY	DATE
B	REVISED DRAWING TO SINGLE ASSEMBLY	SP1	ADB	11/18/2025
A	ADDED VIEWS FOR CLARITY	SP1	ADB	9/16/2025
REVISION HISTORY				

PATENT INFORMATION: WWW.SITEPRO1.COM/PATENTS

CPD NO.	DRAWN BY	ENG. APPROVAL
SP1	SDR 3/6/2026	3/11/2026
CLASS	DRAWING USAGE	CHECKED BY
87	CUSTOMER	CSL 3/11/2026

PART NO.	DWG. NO.
FACE-ASY1-NP	FMW20-3SS

PARTS LIST						
ITEM	QTY	PART NO.	PART DESCRIPTION	LENGTH	UNIT WT.	NET WT.
1	1	X-FACE-TA	TAPER ADJUSTMENT WELDMENT		20.84	20.84
2	1	X-FACE-CP	CONNECTION PLATE	12 in	4.80	4.80
3	2	X-FACE-SB	SPACER BRACKET (WASHER)	6 3/4 in	0.45	0.90
4	6	G58R-8	5/8" x 8" THREADED ROD (HDG.)		0.70	4.18
5	8	G58FW	5/8" HDG USS FLATWASHER	1/8 in	0.07	0.56
6	12	G58LW	5/8" HDG LOCKWASHER		0.03	0.31
7	12	G58NUT	5/8" HDG HEAVY 2H HEX NUT		0.13	1.56
					TOTAL WT. #	

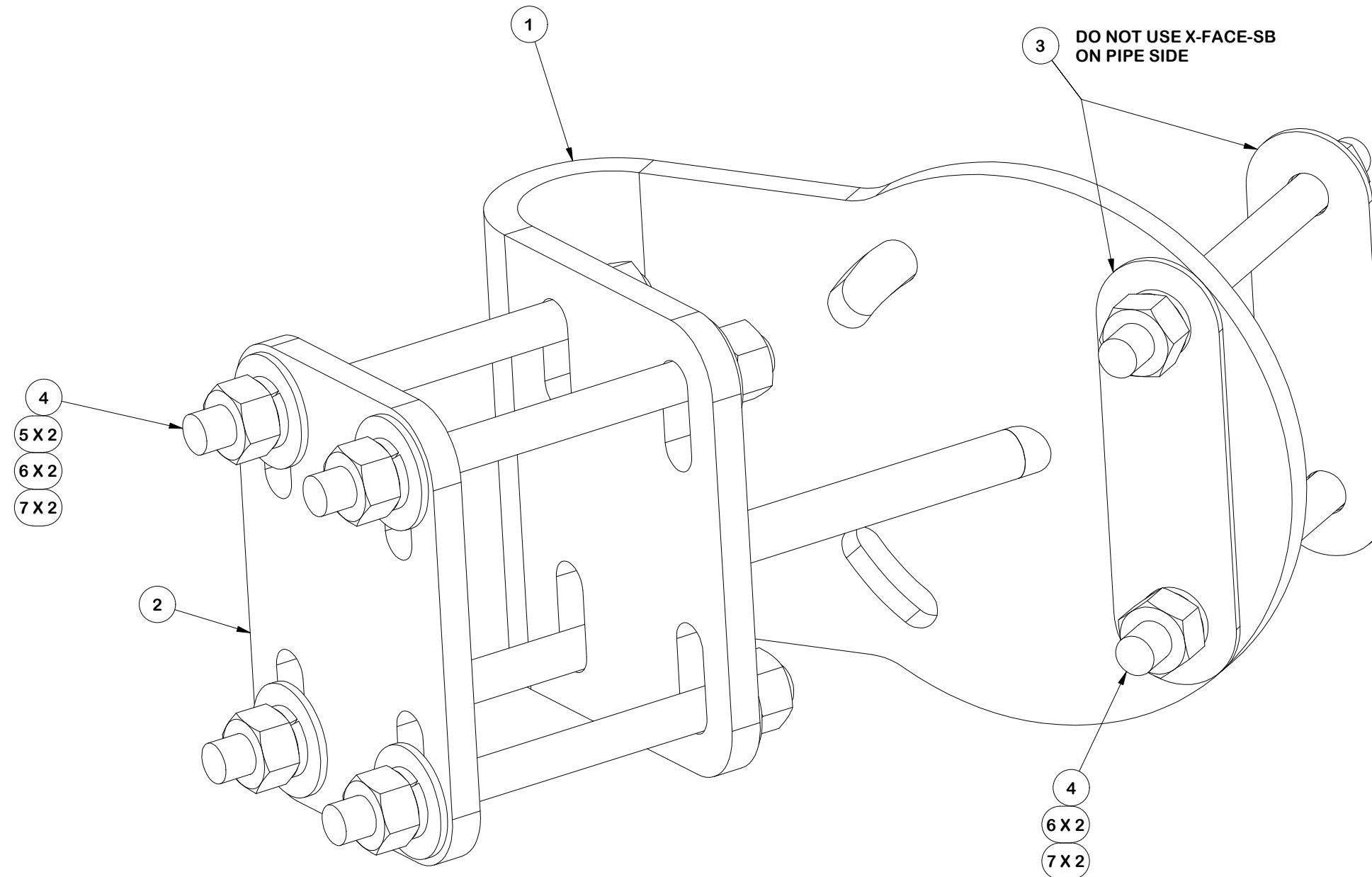

FINISH:
HOT DIP GALVANIZED.

TOLERANCE NOTES

TOLERANCES ON DIMENSIONS, UNLESS OTHERWISE NOTED ARE:
 SAWED, SHEARED AND GAS CUT EDGES ($\pm 0.030"$)
 DRILLED AND GAS CUT HOLES ($\pm 0.030"$) - NO CONING OF HOLES
 LASER CUT EDGES AND HOLES ($\pm 0.010"$) - NO CONING OF HOLES
 BENDS AND ANGLES ARE $\pm 1/2$ DEGREE
 ALL OTHER MACHINING ($\pm 0.030"$)
 ALL OTHER ASSEMBLY ($\pm 0.060"$)

PATENT INFORMATION: WWW.SITEPRO1.COM/PATENTS

PROPRIETARY NOTE:
 THE DATA AND TECHNIQUES CONTAINED IN THIS DRAWING ARE PROPRIETARY INFORMATION OF VALMONT INDUSTRIES AND CONSIDERED A TRADE SECRET. ANY USE OR DISCLOSURE WITHOUT THE CONSENT OF VALMONT INDUSTRIES IS STRICTLY PROHIBITED.

DESCRIPTION
**SINGLE-SECTOR MICROWAVE KIT
 W/ 3-1/2" DIA. X 252" HORIZONTALS
 AND PIPE MOUNT AND SINGLE STRUT**

CPD NO. SP1	DRAWN BY SDR 3/6/2026	ENG. APPROVAL 3/11/2026
CLASS 87	SUB 02	DRAWING USAGE CUSTOMER
CHECKED BY CSL 3/11/2026		



A valmont COMPANY

Engineering Support Team:
 sp1engineering@valmont.com

PART NO.	
DWG. NO.	FMW20-3SS

PARTS LIST						
ITEM	QTY	PART NO.	PART DESCRIPTION	LENGTH	UNIT WT.	NET WT.
1	1	X-FACE-BP	BENT PLATE FOR X-HDCAMTBW	13 in	18.08	18.08
2	4	G58R-14	5/8" x 14" THREADED ROD (HDG.)		1.22	4.88
3	4	G58R-8	5/8" x 8" THREADED ROD (HDG.)		0.70	2.79
4	8	G58LW	5/8" HDG LOCKWASHER		0.03	0.21
5	8	G58NUT	5/8" HDG HEAVY 2H HEX NUT		0.13	1.04
					TOTAL WT. #	26.99

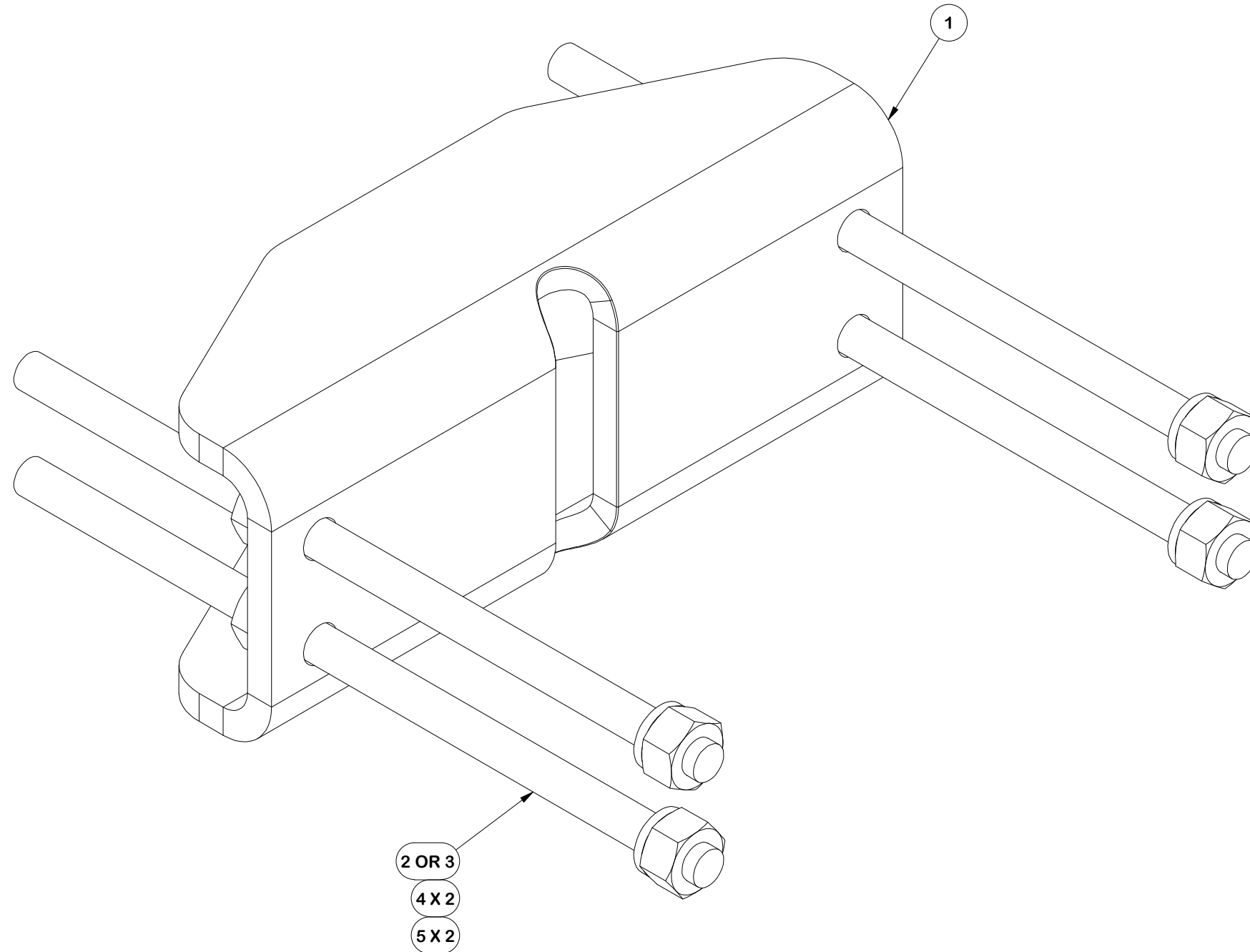

FINISH:
HOT DIP GALVANIZED.

TOLERANCE NOTES

TOLERANCES ON DIMENSIONS, UNLESS OTHERWISE NOTED ARE:
 SAWED, SHEARED AND GAS CUT EDGES ($\pm 0.030"$)
 DRILLED AND GAS CUT HOLES ($\pm 0.030"$) - NO CONING OF HOLES
 LASER CUT EDGES AND HOLES ($\pm 0.010"$) - NO CONING OF HOLES
 BENDS AND ANGLES ARE $\pm 1/2$ DEGREE
 ALL OTHER MACHINING ($\pm 0.030"$)
 ALL OTHER ASSEMBLY ($\pm 0.060"$)

PATENT INFORMATION: WWW.SITEPRO1.COM/PATENTS

PROPRIETARY NOTE:
 THE DATA AND TECHNIQUES CONTAINED IN THIS DRAWING ARE PROPRIETARY INFORMATION OF VALMONT INDUSTRIES AND CONSIDERED A TRADE SECRET. ANY USE OR DISCLOSURE WITHOUT THE CONSENT OF VALMONT INDUSTRIES IS STRICTLY PROHIBITED.

DESCRIPTION
**SINGLE-SECTOR MICROWAVE KIT
 W/ 3-1/2" DIA. X 252" HORIZONTALS
 AND PIPE MOUNT AND SINGLE STRUT**



Engineering
 Support Team:
 sp1engineering@valmont.com

A valmont COMPANY

CPD NO. SP1	DRAWN BY SDR	3/6/2026	ENG. APPROVAL 3/11/2026
CLASS 87	SUB 02	DRAWING USAGE CUSTOMER	CHECKED BY CSL
		3/11/2026	

PART NO. FACE-LC	PAGE 4 OF 9
DWG. NO. FMW20-3SS	

PARTS LIST									
ITEM	QTY	PART NO.	BOX NO.	PART DESCRIPTION	LENGTH	UNIT WT.	NET WT.		
1	1	P496		4" SCH. 40 PIPE (4.5" O.D. X 0.237" - A53 GR. B Fy=35 ksi min)	96 in	91.60	91.60		
2	2	FCX45-U	P-FCX45-U	HEAVY-DUTY UNIVERSAL CROSSOVER KIT		27.08	54.17		
						TOTAL WT. #	145.77		

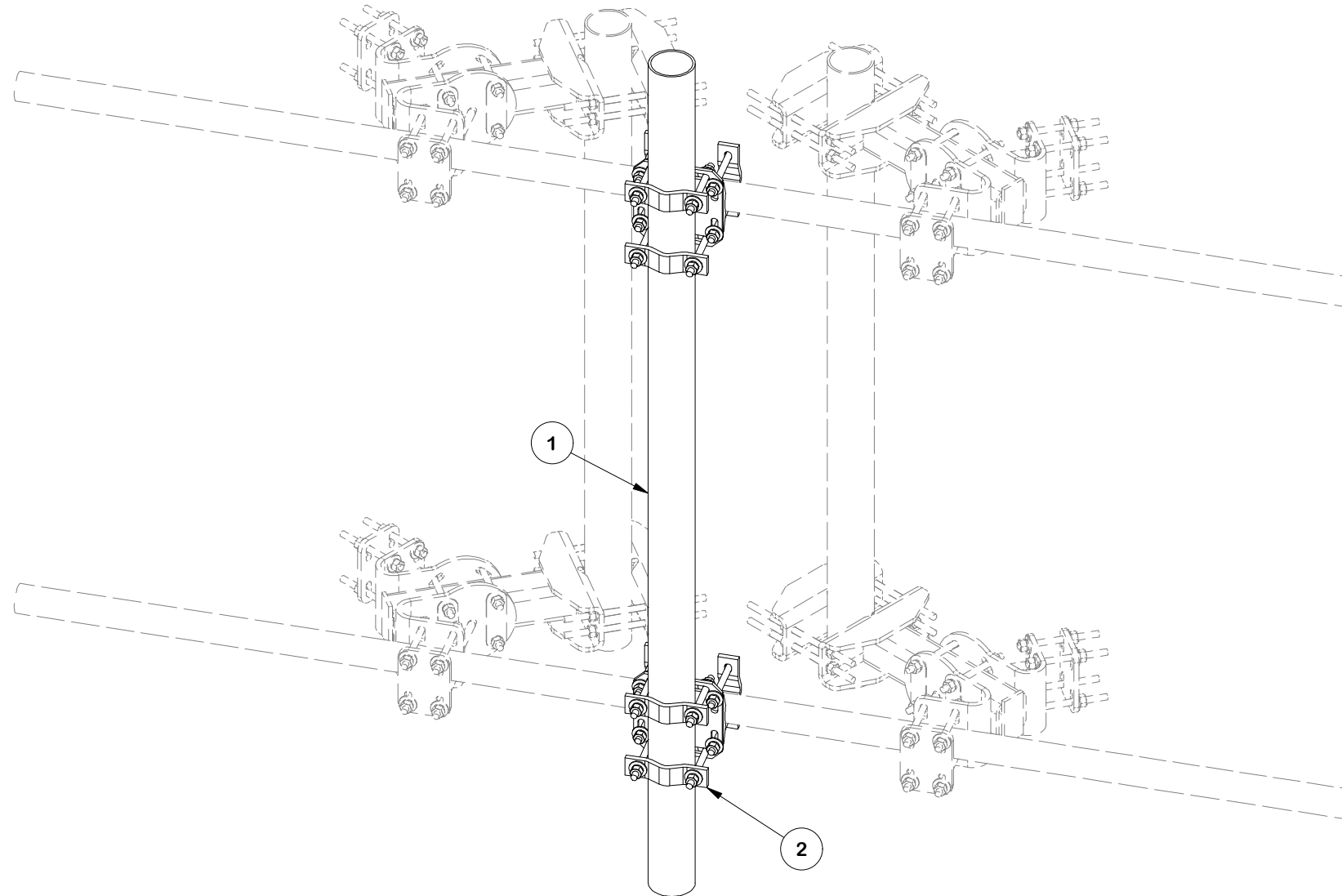

FINISH:
HOT DIP GALVANIZED.

TOLERANCE NOTES

TOLERANCES ON DIMENSIONS, UNLESS OTHERWISE NOTED ARE:
 SAWED, SHEARED AND GAS CUT EDGES ($\pm 0.030"$)
 DRILLED AND GAS CUT HOLES ($\pm 0.030"$) - NO CONING OF HOLES
 LASER CUT EDGES AND HOLES ($\pm 0.010"$) - NO CONING OF HOLES
 BENDS AND ANGLES ARE $\pm 1/2$ DEGREE
 ALL OTHER MACHINING ($\pm 0.030"$)
 ALL OTHER ASSEMBLY ($\pm 0.060"$)

PATENT INFORMATION: WWW.SITEPRO1.COM/PATENTS

PROPRIETARY NOTE:
 THE DATA AND TECHNIQUES CONTAINED IN THIS DRAWING ARE PROPRIETARY INFORMATION OF VALMONT INDUSTRIES AND CONSIDERED A TRADE SECRET. ANY USE OR DISCLOSURE WITHOUT THE CONSENT OF VALMONT INDUSTRIES IS STRICTLY PROHIBITED.

DESCRIPTION
**SINGLE-SECTOR MICROWAVE KIT
 W/ 3-1/2" DIA. X 252" HORIZONTALS
 AND PIPE MOUNT AND SINGLE STRUT**

CPD NO. SP1	DRAWN BY SDR 3/6/2026	ENG. APPROVAL 3/11/2026
CLASS 87	SUB 02	DRAWING USAGE CUSTOMER
CHECKED BY CSL 3/11/2026		



Engineering
 Support Team:
 sp1engineering@valmont.com

A valmont COMPANY

PART NO. FACE-PM496
DWG. NO. FMW20-3SS

PARTS LIST						
ITEM	QTY	PART NO.	PART DESCRIPTION	LENGTH	UNIT WT.	NET WT.
1	1	X-SCX4-FR	4-1/2" FORTRESS CROSSOVER PLATE		8.10	8.10
2	4	DCP	1/2" THICK, 5-3/4" CNTR TO CENTER CLAMP HALF	8 1/8 in	2.36	9.45
3	8	G5807	5/8" x 7" HDG HEX BOLT GR5 FULL THREAD	7 in	0.70	5.64
4	16	G58FW	5/8" HDG USS FLATWASHER	1/8 in	0.07	1.13
5	8	G58LW	5/8" HDG LOCKWASHER		0.03	0.21
6	8	G58NUT	5/8" HDG HEAVY 2H HEX NUT		0.13	1.04
					TOTAL WT. #	

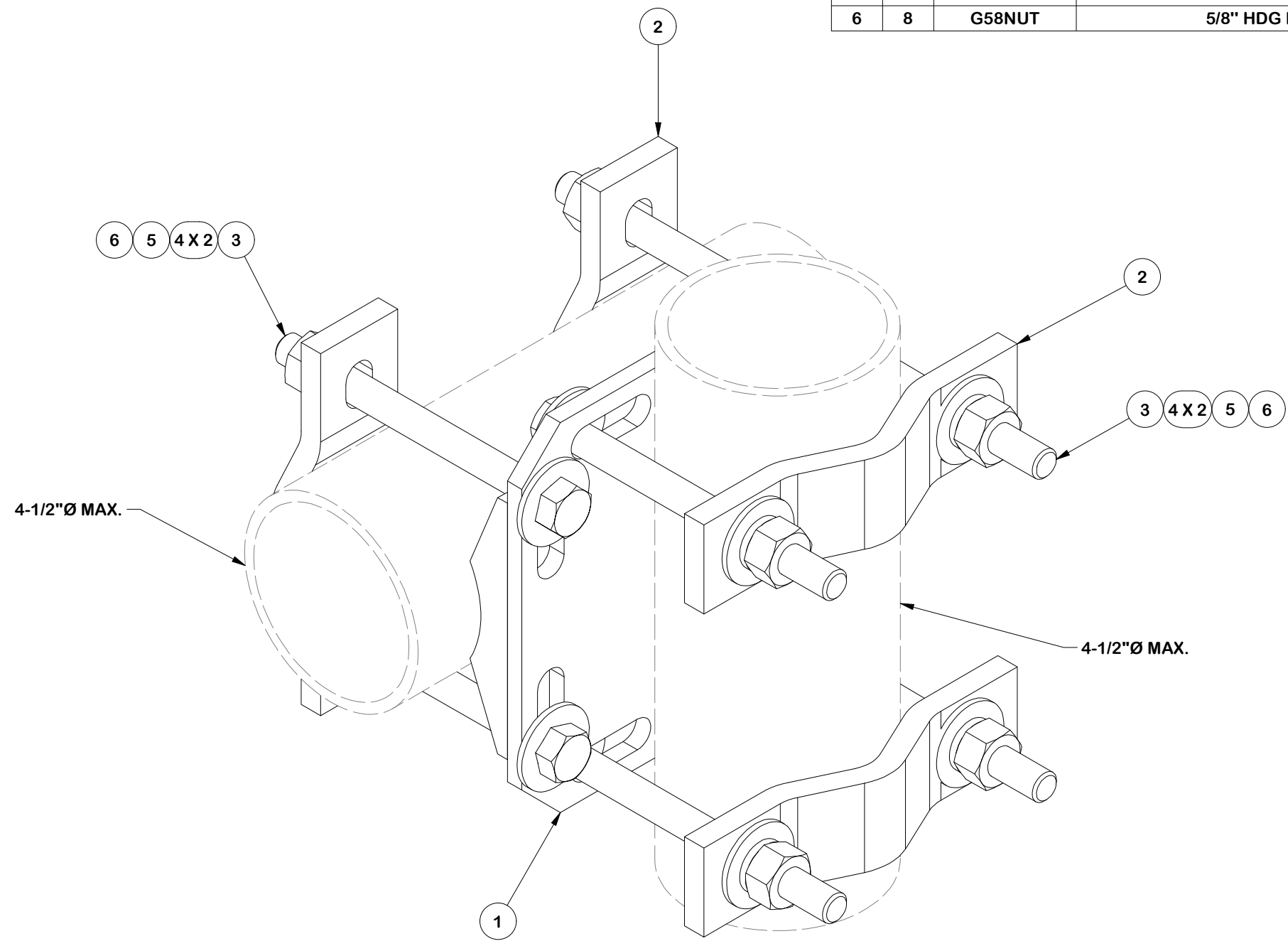

FINISH:
HOT DIP GALVANIZED.

TOLERANCE NOTES

TOLERANCES ON DIMENSIONS, UNLESS OTHERWISE NOTED ARE:
 SAWED, SHEARED AND GAS CUT EDGES ($\pm 0.030"$)
 DRILLED AND GAS CUT HOLES ($\pm 0.030"$) - NO CONING OF HOLES
 LASER CUT EDGES AND HOLES ($\pm 0.010"$) - NO CONING OF HOLES
 BENDS AND ANGLES ARE $\pm 1/2$ DEGREE
 ALL OTHER MACHINING ($\pm 0.030"$)
 ALL OTHER ASSEMBLY ($\pm 0.060"$)

PATENT INFORMATION: WWW.SITEPRO1.COM/PATENTS

PROPRIETARY NOTE:
 THE DATA AND TECHNIQUES CONTAINED IN THIS DRAWING ARE PROPRIETARY INFORMATION OF VALMONT INDUSTRIES AND CONSIDERED A TRADE SECRET. ANY USE OR DISCLOSURE WITHOUT THE CONSENT OF VALMONT INDUSTRIES IS STRICTLY PROHIBITED.

DESCRIPTION
**SINGLE-SECTOR MICROWAVE KIT
 W/ 3-1/2" DIA. X 252" HORIZONTALS
 AND PIPE MOUNT AND SINGLE STRUT**

CPD NO. SP1	DRAWN BY SDR 3/6/2026	ENG. APPROVAL 3/11/2026
CLASS 87	SUB 02	DRAWING USAGE CUSTOMER
CHECKED BY CSL 3/11/2026		



Engineering Support Team:
 sp1engineering@valmont.com

PART NO.	
DWG. NO.	FMW20-3SS

PARTS LIST									
ITEM	QTY	PART NO.	BOX NO.	PART DESCRIPTION	LENGTH	UNIT WT.	NET WT.		
1	1	P296		2" SCH. 40 PIPE (2.375" O.D. X 0.154" - A53 GR. B Fy=35 ksi min)	96 in	32.60	32.60		
2	2	SCX7-U	P-SCX7-U	UNIVERSAL CROSSOVER PLATE KIT		17.94	35.88		
3	1	MSS-U		UNIVERSAL MICROWAVE STRUT SUPPORT		11.60	11.60		
						TOTAL WT. #	92.64		

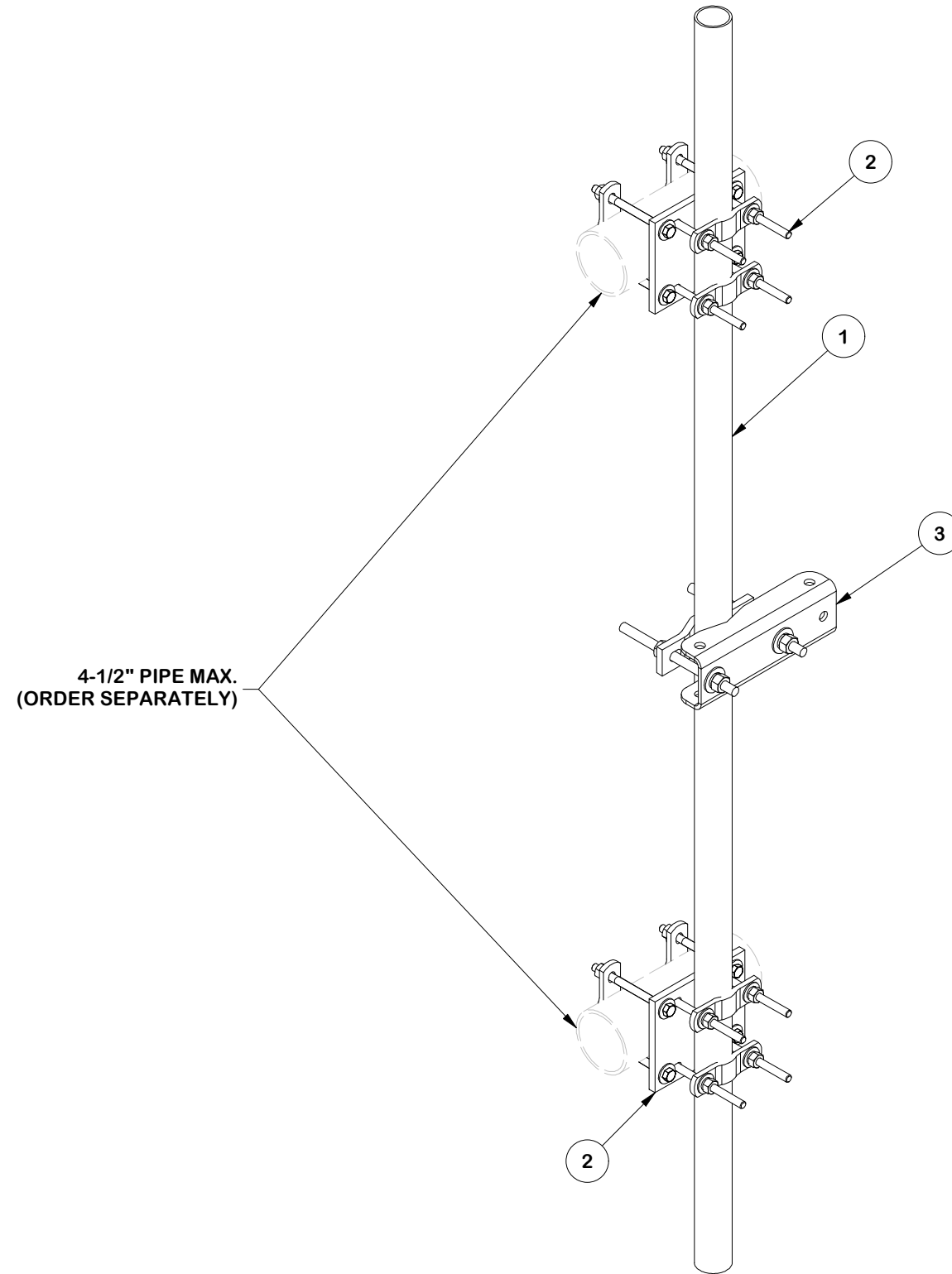

FINISH:
HOT DIP GALVANIZED.

TOLERANCE NOTES

TOLERANCES ON DIMENSIONS, UNLESS OTHERWISE NOTED ARE:
 SAWED, SHEARED AND GAS CUT EDGES ($\pm 0.030"$)
 DRILLED AND GAS CUT HOLES ($\pm 0.030"$) - NO CONING OF HOLES
 LASER CUT EDGES AND HOLES ($\pm 0.010"$) - NO CONING OF HOLES
 BENDS AND ANGLES ARE $\pm 1/2$ DEGREE
 ALL OTHER MACHINING ($\pm 0.030"$)
 ALL OTHER ASSEMBLY ($\pm 0.060"$)

PATENT INFORMATION: WWW.SITEPRO1.COM/PATENTS

PROPRIETARY NOTE:
 THE DATA AND TECHNIQUES CONTAINED IN THIS DRAWING ARE PROPRIETARY INFORMATION OF VALMONT INDUSTRIES AND CONSIDERED A TRADE SECRET. ANY USE OR DISCLOSURE WITHOUT THE CONSENT OF VALMONT INDUSTRIES IS STRICTLY PROHIBITED.

DESCRIPTION
**SINGLE-SECTOR MICROWAVE KIT
 W/ 3-1/2" DIA. X 252" HORIZONTALS
 AND PIPE MOUNT AND SINGLE STRUT**

CPD NO. SP1	DRAWN BY SDR 3/6/2026	ENG. APPROVAL 3/11/2026
CLASS 87	SUB 02	DRAWING USAGE CUSTOMER
CHECKED BY CSL 3/11/2026		



Engineering Support Team:
 sp1engineering@valmont.com

A valmont COMPANY

PART NO. FSP296-K	PAGE 7 OF 9
DWG. NO. FMW20-3SS	

PARTS LIST						
ITEM	QTY	PART NO.	PART DESCRIPTION	LENGTH	UNIT WT.	NET WT.
1	1	SCX7	CROSSOVER PLATE	8 in	8.00	8.00
2	2	X-115765	5" V-CLAMP	7 1/16 in	1.09	2.17
3	2	X-100064	CLAMP (4" V-CLAMP) GALVANIZED	6 in	0.92	1.84
4	8	G12065	1/2" x 6-1/2" HDG HEX BOLT GR5 FULL THREAD	6 1/2 in	0.41	3.28
5	4	G12045	1/2" x 4.5" HDG HEX BOLT GR5 FULL THREAD	4 1/2 in	0.30	1.19
6	20	G12FW	1/2" HDG USS FLATWASHER	3/32 in	0.03	0.68
7	9	G12LW	1/2" HDG LOCKWASHER	1/8 in	0.01	0.13
8	9	G12NUT	1/2" HDG HEAVY 2H HEX NUT	7/8 in	0.07	0.64
					TOTAL WT. #	

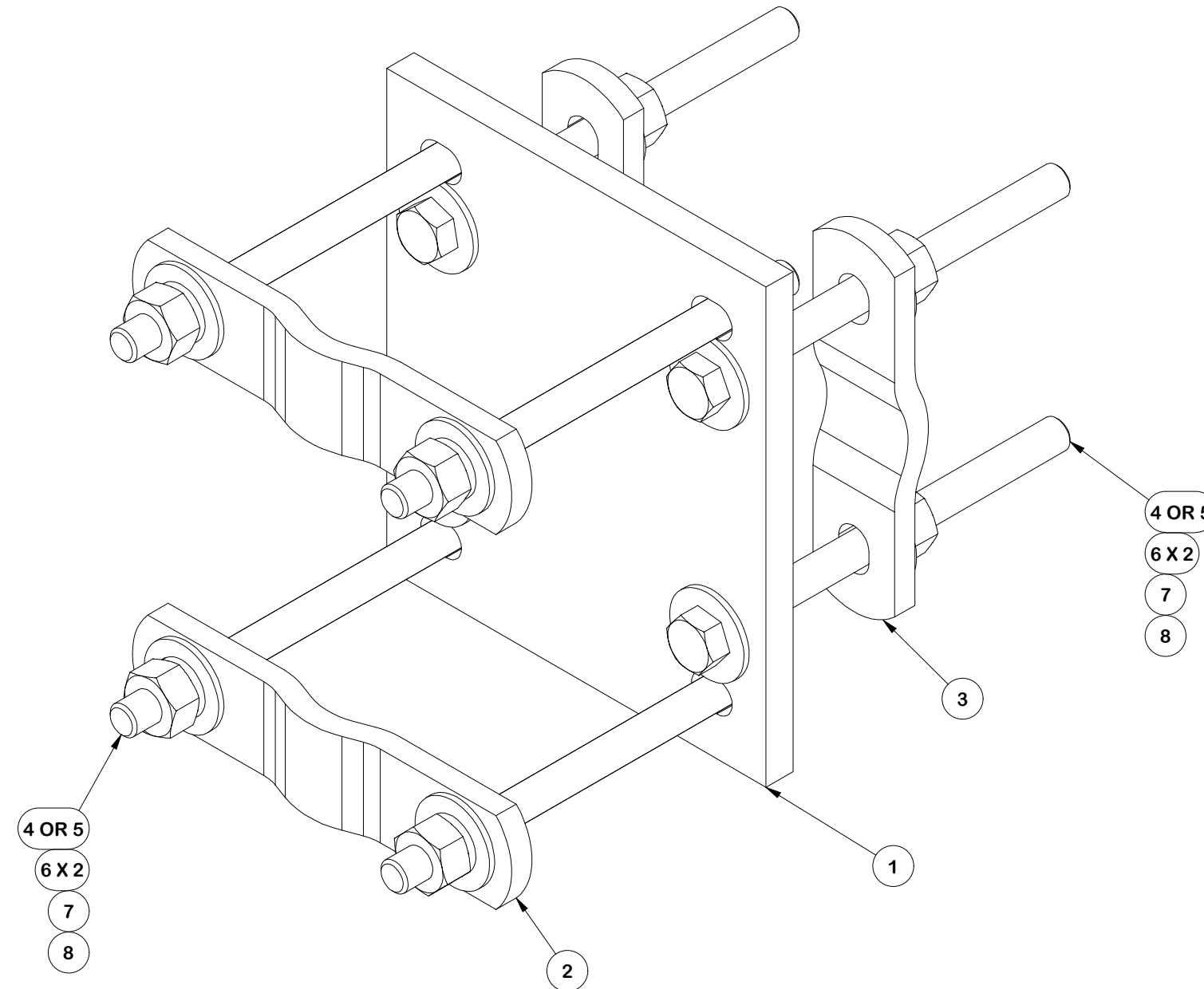

FINISH:
HOT DIP GALVANIZED.

TOLERANCE NOTES

TOLERANCES ON DIMENSIONS, UNLESS OTHERWISE NOTED ARE:
 SAWED, SHEARED AND GAS CUT EDGES ($\pm 0.030"$)
 DRILLED AND GAS CUT HOLES ($\pm 0.030"$) - NO CONING OF HOLES
 LASER CUT EDGES AND HOLES ($\pm 0.010"$) - NO CONING OF HOLES
 BENDS AND ANGLES ARE $\pm 1/2$ DEGREE
 ALL OTHER MACHINING ($\pm 0.030"$)
 ALL OTHER ASSEMBLY ($\pm 0.060"$)

PATENT INFORMATION: WWW.SITEPRO1.COM/PATENTS

PROPRIETARY NOTE:
 THE DATA AND TECHNIQUES CONTAINED IN THIS DRAWING ARE PROPRIETARY INFORMATION OF VALMONT INDUSTRIES AND CONSIDERED A TRADE SECRET. ANY USE OR DISCLOSURE WITHOUT THE CONSENT OF VALMONT INDUSTRIES IS STRICTLY PROHIBITED.

DESCRIPTION
**SINGLE-SECTOR MICROWAVE KIT
 W/ 3-1/2" DIA. X 252" HORIZONTALS
 AND PIPE MOUNT AND SINGLE STRUT**



Engineering
 Support Team:
 sp1engineering@valmont.com

CPD NO. SP1	DRAWN BY SDR 3/6/2026	ENG. APPROVAL 3/11/2026
CLASS 87	SUB 02	DRAWING USAGE CUSTOMER
CHECKED BY CSL 3/11/2026		

PART NO.	
DWG. NO.	FMW20-3SS

PARTS LIST						
ITEM	QTY	PART NO.	PART DESCRIPTION	LENGTH	UNIT WT.	NET WT.
1	1	X-MSS-BPL	MICROWAVE STRUT SUPPORT BENT PLATE	12 in	6.59	6.59
2	1	DCP	1/2" THICK, 5-3/4" CNTR TO CENTER CLAMP HALF	8 1/8 in	2.36	2.36
3	2	G58R-10	5/8" x 10" THREADED ROD (HDG.)		0.87	1.74
4	4	G58FW	5/8" HDG USS FLATWASHER	1/8 in	0.07	0.28
5	4	G58LW	5/8" HDG LOCKWASHER		0.03	0.10
6	4	G58NUT	5/8" HDG HEAVY 2H HEX NUT		0.13	0.52
					TOTAL WT. #	

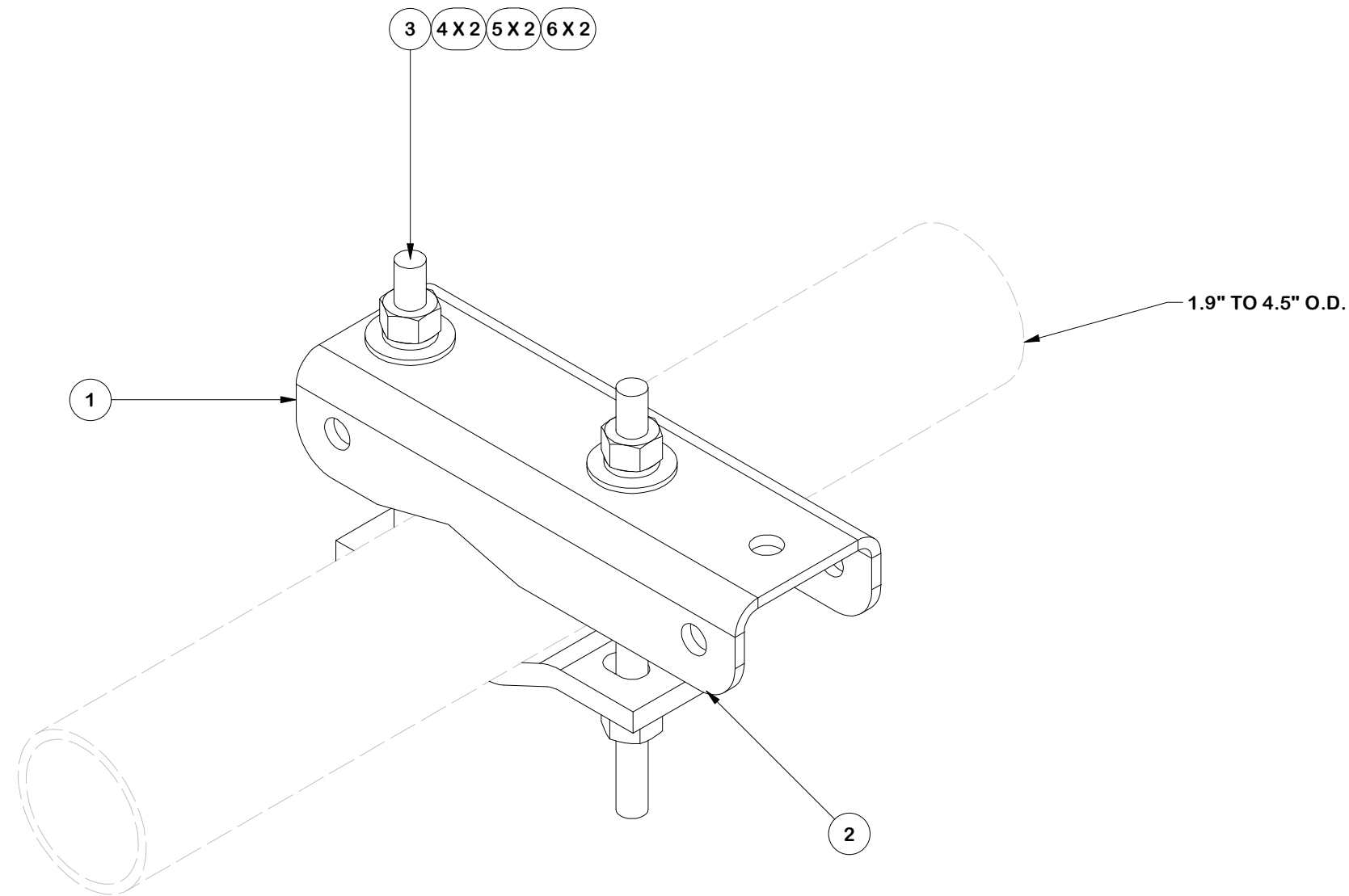

FINISH:
HOT DIP GALVANIZED.

TOLERANCE NOTES

TOLERANCES ON DIMENSIONS, UNLESS OTHERWISE NOTED ARE:
 SAWED, SHEARED AND GAS CUT EDGES ($\pm 0.030"$)
 DRILLED AND GAS CUT HOLES ($\pm 0.030"$) - NO CONING OF HOLES
 LASER CUT EDGES AND HOLES ($\pm 0.010"$) - NO CONING OF HOLES
 BENDS AND ANGLES ARE $\pm 1/2$ DEGREE
 ALL OTHER MACHINING ($\pm 0.030"$)
 ALL OTHER ASSEMBLY ($\pm 0.060"$)

PATENT INFORMATION: WWW.SITEPRO1.COM/PATENTS

PROPRIETARY NOTE:
 THE DATA AND TECHNIQUES CONTAINED IN THIS DRAWING ARE PROPRIETARY INFORMATION OF VALMONT INDUSTRIES AND CONSIDERED A TRADE SECRET. ANY USE OR DISCLOSURE WITHOUT THE CONSENT OF VALMONT INDUSTRIES IS STRICTLY PROHIBITED.

DESCRIPTION
**SINGLE-SECTOR MICROWAVE KIT
 W/ 3-1/2" DIA. X 252" HORIZONTALS
 AND PIPE MOUNT AND SINGLE STRUT**



Engineering
 Support Team:
 sp1engineering@valmont.com

A valmont COMPANY

CPD NO. SP1	DRAWN BY SDR	3/6/2026	ENG. APPROVAL 3/11/2026
CLASS 87	SUB 02	DRAWING USAGE CUSTOMER	CHECKED BY CSL
			3/11/2026

PART NO.	
DWG. NO.	FMW20-3SS